

AMERICAN OUTDOOR GRILL

24 & 36 SERIES OUTDOOR GAS BARBECUES PORTABLE MODEL

INSTALLATION AND OPERATING INSTRUCTIONS



SAFETY WARNINGS & CODES

Important: Read these instructions carefully before starting installation.

INSTALLER: Leave these instructions with consumer.

CONSUMER: Retain for future reference.

⚠ WARNING

1. Do not store or use gasoline or other flammable vapors and liquids in the vicinity of this or any other appliance.
2. A propane cylinder not connected for use shall not be stored in the vicinity of this or any other appliance.

⚠ WARNING

Improper installation, adjustment, alteration, service, or maintenance can cause injury or property damage. Refer to this manual. For assistance or additional information consult a qualified, professional installer, service agency, or the gas supplier.

⚠ DANGER

IF YOU SMELL GAS:

1. Shut off the gas to the appliance.
2. Extinguish any open flame.
3. Open lid if equipped with an oven.
4. If odor continues, keep away from the appliance, and immediately call the gas supplier or fire department.

CODE AND SUPPLY REQUIREMENTS: This barbecue must be installed in accordance with local codes and ordinances, or, in the absence of local codes, with either the latest *National Fuel Gas Code* (ANSI Z223.1/NFPA 54), and *Natural Gas and Propane Installation Code* (CSA-B149.1).

This appliance and its individual shutoff valves must be disconnected from the gas supply piping system when testing the system at pressures in excess of ½ psig (3.5 kPa).

This appliance must be isolated from the gas supply piping system by closing its individual manual shutoff valves during any pressure testing of the gas supply system at pressures up to and including ½ psig (3.5 kPa).

All electrical outlets in the vicinity of the barbecue must be properly grounded in accordance with local codes or, in the absence of local codes, with the *National Electrical Code, ANSI/NFPA 70*, or the *Canadian Electrical Code, CSA C22.1*, whichever is applicable.

Keep all electrical supply cords and fuel supply hoses away from any heated surface.

Certified to ANSI:
Z21.58-2005



AMERICAN OUTDOOR GRILL

24 et 36 SÉRIES LE GAZ EXTÉRIEUR GRILLE TOUT ENTIER LE MODÈLE PORTATIF

INSTALLATION ET CONSIGNES D'UTILISATION



CONDITIONS DE CODE ET D'APPROVISIONNEMENT:

Ce barbecue doit être installé selon des codes et des ordonnances locaux, ou, en l'absence des codes locaux, avec l'un ou l'autre le plus défunt code national de gaz de carburant (norme ANSI Z223.1/NFPA 54), et le code d'installation de gaz naturel et de propane (CSA-B149.1).

Cet appareil et ses différents robinets d'isolement doivent être démontés du système sifflant d'offre de gaz en examinant le système aux pressions au-dessus du ½ psig (kPa 3.5).

Cet appareil doit être isolé dans le système sifflant d'offre de gaz par fermeture ses différents robinets d'isolement manuels pendant tous les essais sous pression du circuit d'alimentation de gaz aux pressions jusques et y compris le ½ psig (kPa 3.5).

Toutes les sorties électriques à proximité du barbecue doivent être correctement fondues selon des codes locaux ou, en l'absence des codes locaux, avec le *code électrique national, ANSI/NFPA 70, ou le code électrique canadien, CSA C22.1, qui est jamais applicable.*

Gardez tout cordon d'alimentation électrique et tuyau d'alimentation en combustible à l'écart des surfaces chauffées.



AVERTISSEMENTS ET CODES DE SÛRETÉ

Important: Lisez ces instructions soigneusement avant de commencer l'installation.

INSTALLATEUR: Laissez ces instructions avec le consommateur.

CONSUMMATEUR: Maintenez pour la future référence.

⚠ AVERTISSEMENT

1. Ne pas entreposer ni utiliser de l'essence ni d'autres vapeurs ou liquides inflammables dans le voisinage de l'appareil, ni de proximité de tout autre appareil.
2. Une bouteille de propane qui n'est pas raccordée en vue de son utilisation, ne doit pas être entreposée dans le voisinage de cet appareil ou de tout autre appareil.

⚠ AVERTISSEMENT

L'installation inexacte, l'ajustement, le changement, le service ou l'entretien peuvent causer des dommages ou des dégâts matériels. Référez-vous à ce manuel. Pour l'aide ou l'information additionnelle consultez un installateur qualifié et professionnel, l'agence de service, ou le fournisseur de gaz.

⚠ DANGER

S'il y a une odeur de gaz:

1. Coupez l'admission de gaz de l'appareil.
2. Éteindre toute flamme nue.
3. Ouvrir le couvercle.
4. Si l'odeur persiste, gardez loin de l'appareil, et appelez immédiatement le fournisseur de gaz ou le service d'incendie.



Certifié à la norme
ANSI : Z21.58-2005



TABLE OF CONTENTS

SAFETY WARNINGS & CODES	1
PRODUCT DATA TABLE	3
PARTS LIST	5
PARTS LIST (Cont.)	6
ROTISSERIE KIT	6
PLANNING THE LOCATION OF THE BARBECUE	7
GAS SUPPLY REQUIREMENTS	7
SAFE USE & MAINTENANCE OF PROPANE GAS CYLINDERS	9
CHECKING AND CONVERTING GAS TYPE	10
CHECKING AND CONVERTING THE REGULATOR	10
CHECKING/CONVERTING THE BURNER ORIFICES	11
MAIN BURNER ORIFICE SIZE CHECKING/CONVERSION	11
MAIN BURNER AIR SHUTTER ADJUSTMENT	11
BACKBURNER ORIFICE SIZE CHECKING/CONVERSION (IF EQUIPPED)	12
SIDEburnER ORIFICE SIZE CHECKING/CONVERSION (IF EQUIPPED)	13
SIDEburnER AIR SHUTTER ADJUSTMENT	13
LIGHTING (IGNITION) INSTRUCTIONS	15
ELECTRONIC LIGHTING	15
MANUAL LIGHTING	15
BARBECUE SAFETY INFORMATION & MAINTENANCE	16
DRIP COLLECTION SYSTEM	16
ROTISSERIE INSTRUCTIONS	17
USING THE BACKBURNER AND ROTISSERIE	17
PUTTING THE MEAT ON THE SPIT ROD	17
RUNNING THE ROTISSERIE	17
RIGID SHELF INSTALLATION	18
ACCESSORIES	19
USING THE GRILL SCRAPER	19
USING THE COOKING GRILL LIFTER	19
DRIP PAN	19
THE VAPORIZER PANEL(S)	19
WARMING RACK	19
BARBECUE CARE & CLEANING	20
BARBECUE COVER	20
REPLACING THE IGNITOR BATTERY	21
TROUBLESHOOTING	21
AMERICAN OUTDOOR GRILL LIMITED WARRANTY	22

PRODUCT DATA TABLE

Specification	Value
Main Burner	24
BTU per burner	16,000 (4.7 kw)
Natural gas orifice	#46 (2.057 mm)
Propane gas orifice	#1.20 (1.20 mm)

Specification	Value
Main Burner	36
BTU per burner	16,000 (4.7 kw)
Natural gas orifice	#46 (2.057 mm)
Propane gas orifice	#1.20 (1.20 mm)

Specification	Value
Sideburner	
BTU per burner	12,000 (3.5 kw)
Natural gas orifice	#53 (1.511 mm)
Propane gas orifice	#63 (0.940 mm)

Specification	Value
Backburner	
BTU per burner	10,000 (2.9 kw)
Natural gas orifice	#54 (1.397 mm)
Propane gas orifice	#65 (0.889 mm)

Table 1 - Product data table

Avertissements généraux :

- Ce barbecue est pour utilisation à l'extérieur seulement. Si l'appareil est entreposé à l'intérieur, enlever les bouteilles et les laisser à l'extérieur.
- Ne pas ranger le gril immédiatement après l'avoir utilisé. le laisser refroidir avant de le déplacer ou de la ranger. Le non respect de cette mesure de sécurité pourrait entraîner un incendie causant des dommages à la propriété, des blessures ou la mort.
- Ne pas utiliser cet appareil sous une surface combustible.
- Ne pas utiliser cet appareil sous un auvent. Le non respect de cette mesure de sécurité pourrait entraîner un incendie ou des blessures.
- Dégagement minimal entre les parois latérales et l'arrière de l'appareil et la construction combustible (45.7 cm à partir des parois latérales et 45.7cm à partir de l'arrière).
- Le régulateur de pression de gaz prévu avec cet appareil de cuisson à gaz pour l'extérieur doit être utilisé. Ce régulateur est réglé pour une pression de sortie de 5 pouces de colonne de l'eau pour le gaz naturel, et 10 pouces pour le propane.
- LE RÉGULATEUR INCLUS D'APPAREILS EST ÉVALUÉ POUR LE MAXIMUM DE 1/2 (LIVRES PAR POUCE CARRÉ). SI VOTRE OFFRE DE GAZ EST 1/2 PLUS GRAND QUE (LIVRES PAR POUCE CARRÉ), UN RÉGULATEUR ADDITIONNEL DOIT ÊTRE INSTALLÉ AVANT LE BARBECUE. VOIR LA SECTION DE CONDITIONS D'OFFRE DE GAZ POUR LA PRESSION APPROPRIÉE D'OFFRE DE GAZ.
- Ne couvrez jamais la surface entière de cuisine ou de gril de gauffreuses ou de casseroles. La surchauffe se produira et les brûleurs ne seront pas très performants quand la chaleur de combustion est emprisonnée au-dessous de la surface à cuire.
- Ne pulvérisez jamais l'eau sur une unité chaude de gaz, comme ceci peut endommager des composants de porcelaine ou de fer de fonte.

Avertissements de propane :

- Une fuite de GPL peut causer un incendie ou une explosion si enflammée entraînant des blessures corporelles graves ou la mort.
- Communiquez avec le fournisseur de GPL pour les réparations ou pour disposer de la bouteille ou du GPL non utilisé.

PARTS LIST

Item	Part #	Description
1.	24-B-11	Cooking grids 24" (2)
or	36-B-11	Cooking grids 36" (3)
2.	24-B-05	Vaporizer panels 24" (2)
or	36-B-05	Vaporizer panels 36" (3)
3.	24-B-06	Main burner 24" (2)
or	36-B-06	Main burner 36" (3)
4.	24-B-10	Thermometer
5.	24-B-12	Oven 24"
or	36-B-12	Oven 36"
6.	24-C-02	Single sideburner
7.	24-B-02	Warming rack 24"
or	36-B-02	Warming rack 36"
8.	24-B-07	Rotisserie motor 24"/ 36"
9.	24-B-13	Rotisserie spit rod 24"
or	36-B-13	Rotisserie spit rod 36"
10.	3083	Drip tray with match holder
11.	24-C-14	Face assembly 24"
or	36-C-14	Face assembly 36"
12.	3199-34	Electronic ignitor 24" (1) 36" (2)
13.	24-C-08	Burner manifold 24"
or	36-C-08	Burner manifold 36"
14.	24-B-15	Heatshield 24" (1)
or	36-B-15	Heatshield 36" (2)
15.	24-B-04	Main burner electrode 24"
or	36-B-04	Main burner electrode 36"
16.	3015	Barbecue knobs (2)
17.	3016	Backburner knobs (2)
18.	24-B-17	Backburner

Replacement parts can be ordered from your local AOG dealer.

IMPORTANT

This AOG oven and backburner are fully pre-assembled and tested at the factory.

DO NOT attempt to remove the oven and backburner from the barbecue prior to or during installation or damage to the connecting gas line and ignitor wiring may occur.

The plastic straps that secure the oven to the barbecue unit must be removed and discarded prior to lighting.

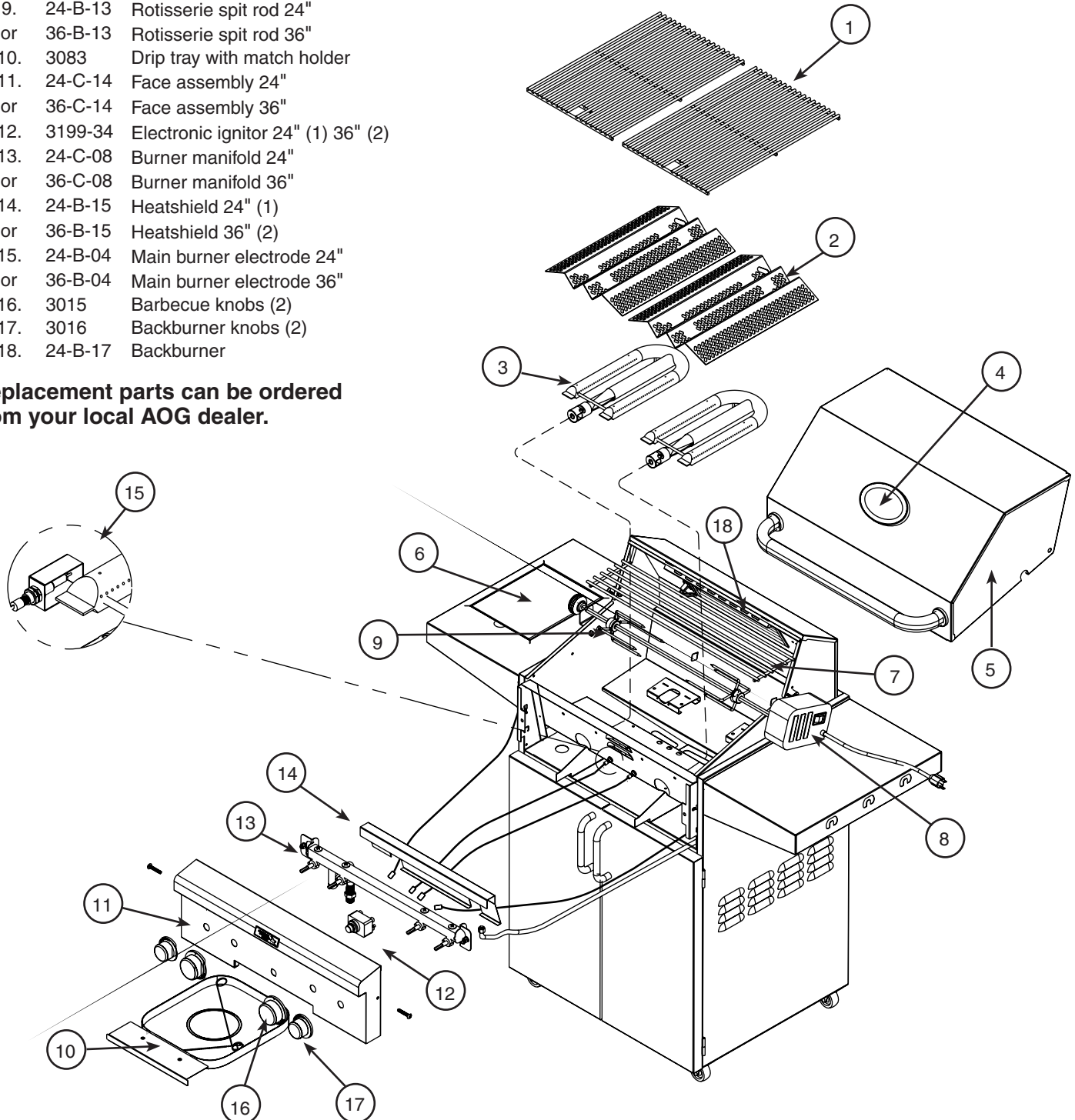

ROTISSERIE KIT

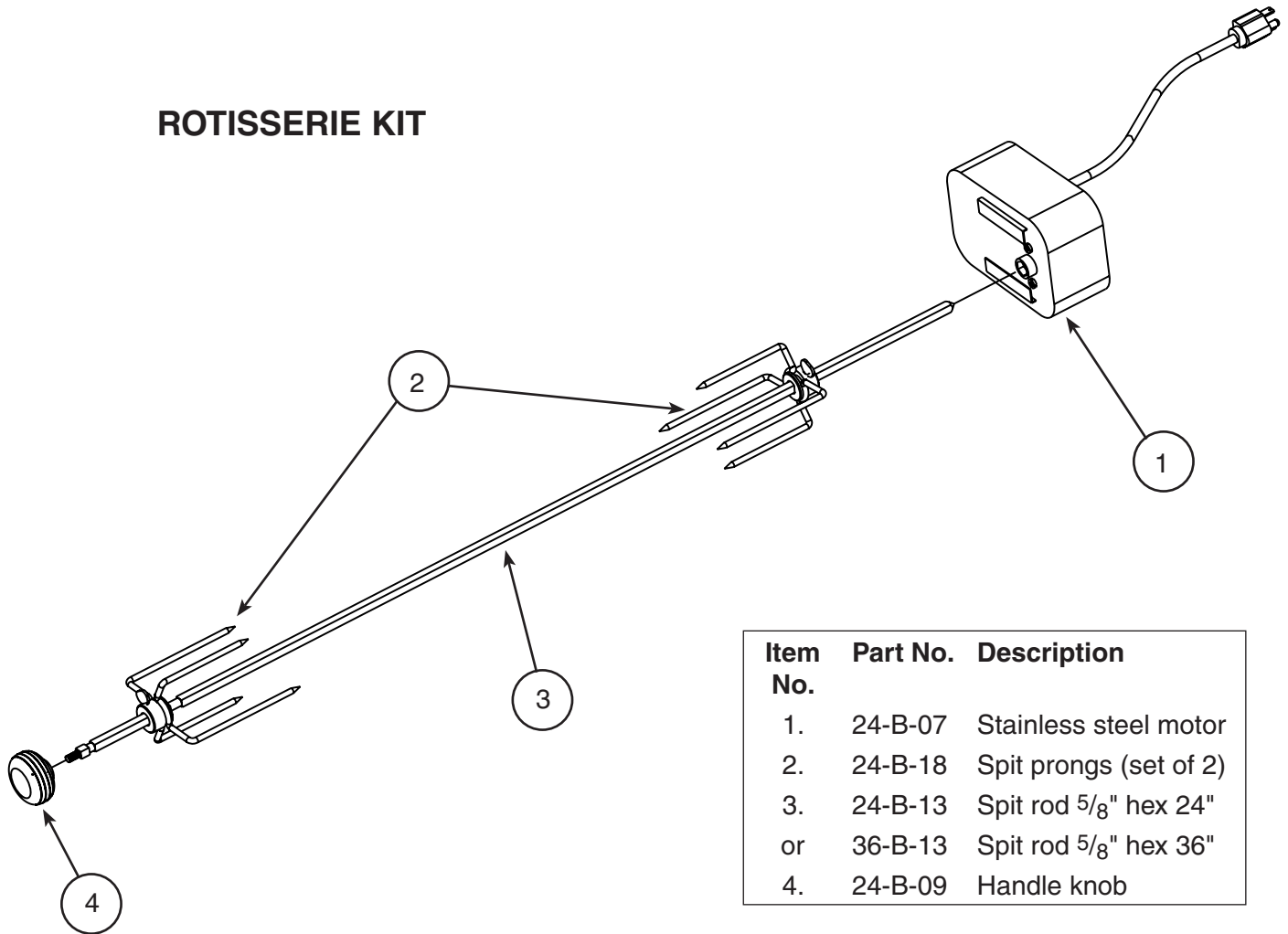

Item No.	Part No.	Description
1.	24-B-07	Stainless steel motor
2.	24-B-18	Spit prongs (set of 2)
3.	24-B-13	Spit rod $\frac{5}{8}$ " hex 24"
	or 36-B-13	Spit rod $\frac{5}{8}$ " hex 36"
4.	24-B-09	Handle knob

PLANNING THE LOCATION OF THE BARBECUE

This barbecue is designed for outdoor use only.

DO NOT use this unit under unprotected flammable surfaces. DO NOT use this appliance inside a building, garage, or any other covered area (see EXHAUST REMOVAL). DO NOT use this barbecue in or on a recreational vehicle or boat.

Important: This unit is NOT insulated, and therefore if an American Outdoor Grill approved insulating liner is not added, the unit must be located with a minimum of 18" (45.7 cm) of side and back clearance from unprotected combustible materials such as wood, plastic, or stucco with wood framing, when in operation.

The face of the unit is removable for servicing and air shutter adjustment (see PARTS LIST).

Note: Keep electrical-supply cords away from all heated surfaces.

ENSURING PROPER COMBUSTION AIR AND COOLING AIRFLOW

You must maintain proper airflow for the barbecue to perform as it was designed (Fig. 7-1). If airflow is blocked, overheating and poor combustion will result. Do not block the 1" (2.5 cm) front air inlet along the bottom of the face or more than 75% of the cooking grid surface with pans or griddles.

Note: The 1" (2.5 cm) front air space allows access to the drip tray.

ELECTRICAL OUTLETS

All electrical outlets in the vicinity of the barbecue must be properly grounded.

EXHAUST REMOVAL

If installed or used under a patio roof, the cooking grid area should be fully covered by a chimney and exhaust hood. An exhaust fan with a rating of 1,000 CFM (cubic feet per minute) (472 liters per second) or more may be necessary to efficiently remove smoke and other cooking by-products from the covered area. This barbecue shall not be used under overhead combustible construction. **THIS UNIT SHOULD NOT BE LOCATED IN A FULLY ENCLOSED AREA OF ANY KIND.**

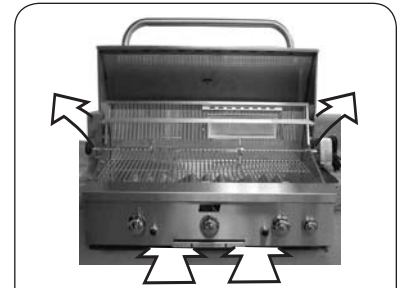

Fig. 7-1 - Ventilation diagram

GAS SUPPLY REQUIREMENTS

GAS-SUPPLY PLUMBING REQUIREMENTS

For natural gas or a household propane system, rigid 1/2" (1.3 cm) or 3/4" (1.9 cm) black steel pipe, or local code-approved pipe, is required to conduct the gas supply to the unit. An outdoor-approved flexible connector can be used to connect the household gas supply to the barbecue. **DO NOT use a rubber hose within the barbecue enclosure.** Apply only joint compounds that are resistant to all gasses on all male pipe fittings. Make sure to tighten every joint securely.

Note: If 1/2" (1.3 cm) pipe is used with **natural gas**, it should be no longer than 20' (6.1 meters).

Important: An external valve (with a removable key) in the gas line is necessary for safety when the barbecue is not in use. It also provides for convenient maintenance.

Natural gas carts are supplied with a quick-connect hose (also available for household propane); see Fig. 7-2.

The quick-connect coupling must be installed after a gas shutoff valve. The coupling socket requires a 1/2" male pipe nipple from the gas supply.

To Connect

1. Pull socket sleeve back (Fig. 7-3).
2. Insert plug and release sleeve.
3. Push plug into socket until sleeve snaps forward.
4. Open gas valve.
5. Test for leaks using soapy water solution.

To Disconnect

1. Close the shutoff valve.
2. Pull sleeve back and pull out plug (Fig. 7-4).

GAS SUPPLY AND MANIFOLD PRESSURES

For **natural gas** - Normal 7" water column (w.c.), minimum 5" w.c., maximum 10-1/2" w.c.

For **propane gas** - Normal 11" w.c., minimum 8" w.c., maximum 13" w.c.

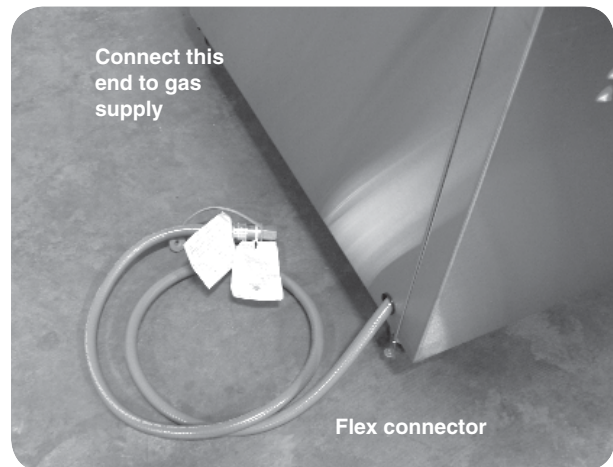

Fig. 7-2 - Natural gas outdoor connector

Quick-disconnect operation

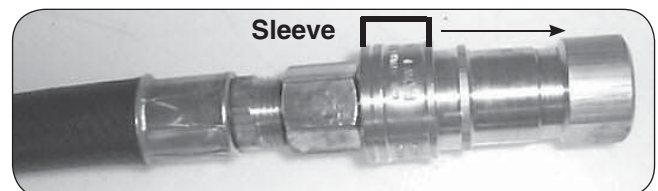

Fig. 7-3 Pull sleeve back

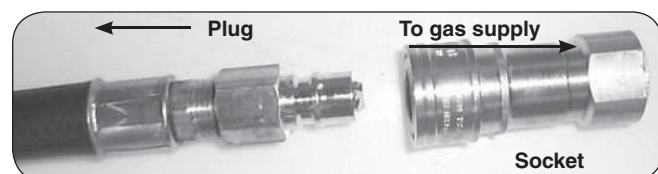

Fig. 7-4 Pull out plug

UTILISATION SÛRE ET ENTRETIEN DES CYLINDRES DE GAZ DE PROPANE

IMPORTANT POUR VOTRE SÛRETÉ

LISEZ ET SUIVEZ TOUS LES AVERTISSEMENTS ÉQUIPÉS DE VOTRE CYLINDRE DE GAZ DE PROPANE.

En actionnant cet appareil avec un cylindre de gaz de propane ON DOIT observer ces instructions et avertissements.

LE MANQUE DE FAIRE AINSI PEUT AVOIR COMME CONSÉQUENCE UNE INCENDIE OU UNE EXPLOSION SÉRIEUSE.

CYLINDRE ET CONDITIONS ET

CARACTÉRISTIQUES DE CONNECTEUR

- Des cylindres et les valves de gaz de propane doivent être maintenus en bon état et doivent être remplacés s'il y a des dommages évidents au cylindre ou à la valve.
- Ce barbecue, une fois utilisé avec un cylindre, devrait être relié à un gallon de la norme 5 (20lb.) cylindre de gaz de propane équipé d'un OPD (remplissez au-dessus du niveau le dispositif d'empêchement). L'OPD a été exigé sur tous les cylindres vendus depuis octobre 1.1998 pour empêcher le remplissage excessif.
- Les dimensions de cylindre devraient être approximativement 12"(30.5cm) de diamètre et 18" (45.7cm) hauts. Des cylindres doivent être construits et marqués selon les caractéristiques pour des cylindres de gaz de propane du département des ETATS-UNIS du transport (D.O.T.) ou le niveau national du Canada, du CAN/CSA-B339, des cylindres, des sphères et des tubes pour le transport des marchandises dangereuses.
- Le cylindre doit inclure un collier pour protéger la valve de cylindre et le circuit d'alimentation de cylindre doit être assuré le retrait de vapeur.
- Le régulateur de pression et l'ensemble de tuyau (fig. 8-1) fourni avec cet appareil à cuire extérieur de gaz doivent être utilisés. Les régulateurs d'original et de pression de remplacement et les ensembles de tuyau doivent être ceux indiqués par le Robert H. Peterson Cie. pour le raccordement avec un dispositif se reliant de cylindre identifié comme type I par la norme ANSI Z 21.58 et CGA 1.6-M95-1995 avec la norme ANSI Z 21.58a -1998 d'addenda et CGA 1.6a - M98.
- La valve de cylindre de gaz de propane doit être équipée d'un dispositif d'accouplement de raccordement de cylindre, décrit comme type I dans la norme définie dans le e. de paragraphe ci-dessus. Ce dispositif est généralement décrit comme coupleur rapide de fil de point culminant.
- Si votre cylindre de gaz de propane vient avec une prise de la poussière, placez le bouchon anti-poussière sur la sortie de valve de cylindre toutes les fois que le cylindre n'est pas en service.

OPÉRATION DE COUPLEUR RAPIDE

Pour relier le régulateur/hose à l'ajustage de précision de valve de cylindre de gaz de propane: Serrez l'écrou de main sur le régulateur au-dessus de l'ajustage de précision de fil de point culminant sur la valve de cylindre. Tournez l'écrou de

main dans le sens des aiguilles d'une montre pour engager les fils et pour serrer jusqu'à ce que douillettement. L'utilisation des pinces ou de la clé ne devrait pas être nécessaire. Seulement le propane marqué par cylindres doit être employé.

Pour débrancher: Tournez l'écrou de main dans le sens contraire des aiguilles d'une montre jusqu'à isolé (fig. 8-1).

Important: Avant d'employer le barbecue, et ensuite chaque fois que le cylindre est enlevé et rattaché, examinez tous les raccordements pour déceler les fuites. Arrêtez les valves de barbecue et ouvrez la valve principale de cylindre, puis vérifiez les raccordements avec de l'eau savonneux. Réparez toutes les fuites avant d'allumer le barbecue.

ATTENTION: Tournez toujours la valve principale de cylindre de propane au loin après chaque utilisation, et avant de déplacer le barbecue et le cylindre, ou débrancher l'accouplement. Cette valve doit rester fermée et le cylindre a débranché alors que l'appareil n'est pas en service, quoique l'écoulement de gaz soit arrêté par un dispositif de sûreté quand le coupleur est débranché.

Inspectez soigneusement l'ensemble de tuyau chaque fois avant que le gaz soit allumé. Un tuyau criqué ou frangé devrait être remplacé immédiatement.

Si l'appareil est stocké à l'intérieur, le cylindre doit être débranché et enlevé. Des cylindres doivent être stockés hors des portes, hors de l'extension des enfants, et ne doivent pas être stockés dans un bâtiment, le garage, ou n'importe quel autre secteur inclus.

POUR VOTRE SÛRETÉ

- Ne stockez pas un cylindre de gaz disponible de propane dessous ou ne vous approchez pas de cet appareil.
- Ne remplissez jamais cylindre au delà de 80 pour cent de plein.
- SI L'INFORMATION DANS "A" ET "B" N'EST PAS SUIVIE EXACTEMENT, UN FEU CAUSANT LA MORT OU DES DOMMAGES SÉRIEUX PEUT SE PRODUIRE.

Fig. 8-1 type coupleur rapide de fil de point culminant d'I

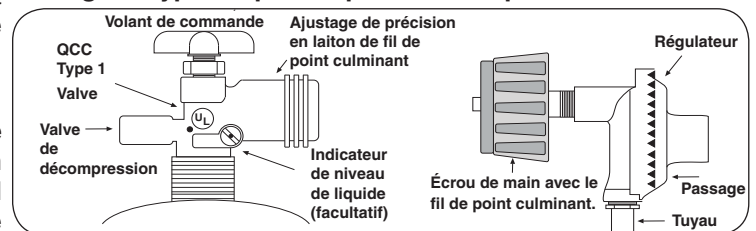

SAFE USE & MAINTENANCE OF PROPANE GAS CYLINDERS

IMPORTANT FOR YOUR SAFETY

READ AND FOLLOW ALL WARNINGS PROVIDED WITH THE PROPANE GAS CYLINDER.

When operating this appliance with a propane gas cylinder, these instructions and warnings **MUST** be observed.

FAILURE TO DO SO MAY RESULT IN A SERIOUS FIRE OR EXPLOSION.

CYLINDER/CONNECTOR REQUIREMENTS

- Propane gas cylinders, valves, and hoses must be maintained in good condition and must be replaced if there is visible damage to either the cylinder or valve. If the hose is cut or shows excessive abrasion or wear, it must be replaced before using the gas appliance (see e.).
- This barbecue, when used with a cylinder, should be connected to a standard 5-gallon (20 lb.) propane gas cylinder equipped with an OPD (Overfill Prevention Device). The OPD has been required on all cylinders sold since October 1, 1998, to prevent overfilling.
- Cylinder dimensions should be approximately 12" (30.5cm) in diameter and 18" (45.7cm) high. Cylinders must be constructed and marked in accordance with the *Specifications for Propane Gas Cylinders of the U.S. Department of Transportation (D.O.T.)* or the National Standard of Canada, *CAN/CSA-B339, Cylinders, Spheres, and Tubes for Transportation of Dangerous Goods*.
- The cylinder must include a collar to protect the cylinder valve and the cylinder supply system must be arranged for vapor withdrawal.
- The pressure regulator and hose assembly (Fig. 9-1) supplied with this outdoor cooking gas appliance must be used. Original and replacement pressure regulator and hose assemblies must be those specified by the Robert H. Peterson Co. for connection with a cylinder connecting device identified as Type I by the *ANSI Z 21.58-2005/CGA 1.6-2005* (see PARTS LIST for ordering information).
- The propane gas cylinder valve must be equipped with a cylinder connection coupling device, described as Type I in the standard defined in paragraph e. above. This device is commonly described as an Acme thread quick coupler.
- If the propane gas cylinder comes with a dust plug, place the dust cap on the cylinder valve outlet whenever the cylinder is not in use.

QUICK COUPLER OPERATION

To connect the regulator/hose assembly to the propane gas cylinder valve fitting: Press the hand nut on the regulator over the Acme thread fitting on the cylinder valve. Turn the hand nut clockwise to engage the threads and tighten until snug.

The use of pliers or a wrench should not be necessary. Only cylinders marked propane may be used.

To disconnect: Turn the hand nut counterclockwise until detached (Fig. 9-1).

Important: Before using the barbecue, and after each time the cylinder is removed and reattached, check the hose for wear (see a.) and check all connections for leaks. Turn off the barbecue valves and open the main cylinder valve, then check connections with soapy water. Repair any leaks before lighting the barbecue.

CAUTION: Always turn the propane cylinder main valve off after each use, and before moving the barbecue and cylinder, or disconnecting the coupling. This valve must remain closed and the cylinder disconnected while the appliance is not in use, even though the gas flow is stopped by a safety feature when the coupler is disconnected.

Carefully inspect the hose assembly each time before the gas is turned on. A cracked or frayed hose should be replaced immediately.

If the appliance is stored indoors, the cylinder must be disconnected and removed. **Cylinders must be stored out of doors, out of the reach of children**, and must not be stored in a building, garage, or any other enclosed area.

FOR YOUR SAFETY

- DO NOT store a spare propane gas cylinder under or near this appliance.
- NEVER fill the cylinder beyond 80 percent full.
- IF THE INFORMATION IN "a" AND "b" IS NOT FOLLOWED EXACTLY, A FIRE CAUSING DEATH OR SERIOUS INJURY MAY OCCUR.

Fig. 9-1 Type I Acme thread quick coupler

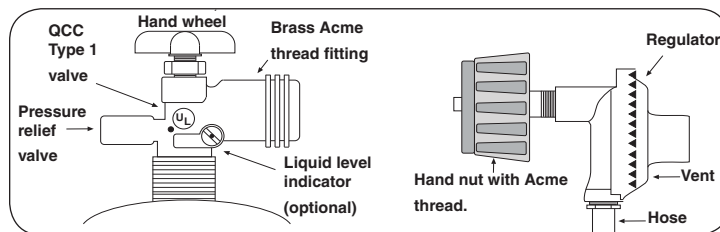

CHECKING AND CONVERTING GAS TYPE

This barbecue comes from the factory configured for one type of gas, as marked on the label behind the barbecue face plate.

Converting this barbecue to burn a different type of gas requires a conversion kit from the factory. The professional installer that converts this barbecue to burn a different gas must perform the following functions:

1. Change replaceable, brass gas orifices (included at original shipping) on each burner to match the new gas type (see PRODUCT DATA TABLE, Table 1).
2. Switch the convertible gas regulator (included at original shipping) to match the new gas type (see below).
3. Plumb the unit to the new gas supply.
4. Apply a new label behind the faceplate, indicating the new gas the barbecue will burn (included with conversion kit). The label must be applied partly on top of the old label so that it covers the old gas type and ratings information but not the serial number and other unchanged data.

WARNING

HAZARDOUS OVERHEATING WILL OCCUR IF A NATURAL GAS ORIFICE IS USED WITH PROPANE GAS. IF YOU ARE NOT SURE IF THE CORRECT ORIFICES ARE INSTALLED, OR IF AN ORIFICE CHANGE IS NECESSARY, REFER TO THE FOLLOWING INSTRUCTIONS.

CAUTION: Make sure the barbecue is at a safe temperature and isolated from gas and electrical supplies before beginning the tasks outlined below.

Note: The cooler the barbecue, the greater the tolerances between the stainless steel parts, and therefore, the easier to disassemble and reassemble parts of the barbecue.

CAUTION: For your safety, exercise caution and use adequate hand protection, such as gloves, when handling potentially sharp sheet-metal parts.

CHECKING AND CONVERTING THE REGULATOR

Barbecue regulator:
note the cap on top

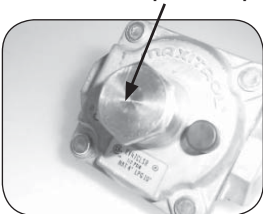

Note: Each end of the plastic converter is engraved with either the letters NAT or L.P. (propane) for the respective gasses. When the converter is in the cap and the cap is held uppermost, the letters seen indicate the gas that the regulator is set up for.

To convert the regulator from one gas to another, follow steps 1-4.



STEP 1:
Unscrew and remove the cap from the regulator, extracting the converter.

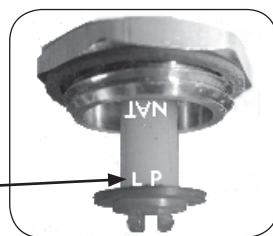

Read gas
type here

STEP 3:
Turn the converter around and replace, carefully, into the center of the cap (it will snap into place). Check that you can read the type of gas the unit is set for.



STEP 2:
Remove the converter (the plastic stalk) by carefully pulling it away from the center of the cap (it will snap out of its seating).

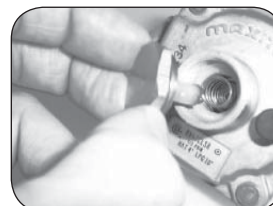

STEP 4:
Replace the unit into the regulator and screw down until snug.

WARNING

THIS APPLIANCE REGULATOR IS RATED FOR 1/2 PSI MAXIMUM. IF YOUR GAS SUPPLY IS GREATER THAN 1/2 PSI, AN ADDITIONAL REGULATOR MUST BE INSTALLED TO REDUCE THE INPUT PRESSURE TO THE BARBECUE TO 1/2 PSI OR LESS. SEE GAS SUPPLY REQUIREMENTS SECTION FOR PROPER GAS SUPPLY PRESSURE.

CHECKING/CONVERTING THE BURNER ORIFICES

MAIN BURNER ORIFICE SIZE CHECKING/ CONVERSION

Before beginning, make sure you have the proper tools for the task.

This task requires:

- a #2 Phillips-head screwdriver
- a deep $\frac{3}{8}$ " nut driver with a spacer (#6 nut)

Note: It may be necessary to remove the rotisserie rod before beginning this procedure.

1. Remove cooking grids & vaporizer panels from the barbecue.
2. **Turn the burner valves to the OFF position.** Pull the valve knobs from their stems and set them aside. Using a Phillips screwdriver, unscrew the face fastener screws, (located on the sides of the face) and remove the face from the barbecue. Retain the screws and finish washers for reattaching the face.

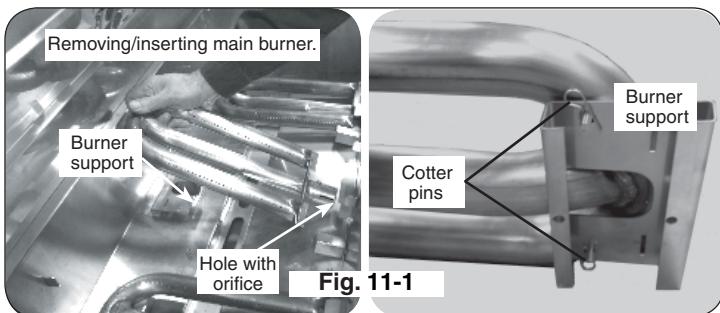

Note: Carefully, lift the face away from the frame. The spark generator for the ignition system is attached to the inside of the face panel. The spark generator knob need not be detached, but the wires must be unplugged from the generator before the face is completely removed (see Fig. 11-2).

3. Remove the two cotter pins from underneath the rear burner support and set them aside. Then carefully lift the burner from the rear burner-support and out from the hole in the forward fire wall (see Fig. 11-1).

4. Using a $\frac{3}{8}$ " socket, remove the orifice from the valve. Access this through the hole in the forward firebox plate (see PARTS LIST and Fig. 11-1). Check the number stamped on the face of the orifice (see Table 1). Repeat for each burner as necessary.

5. If the barbecue does not have the proper orifices installed for the gas supply you intend to use, replace them with the correct orifices. Some orifices were supplied with the barbecue. They may also be obtained from the conversion kit or supplied by your local AOG dealer.

Note: A regulator hose will need to be connected for conversion to propane gas.

6. After checking the orifice drill size or replacing the orifice, replace the burner over the orifice fitting, sliding it forward,



from behind the forward fire wall, so the orifice is centered inside the burner gas inlet, and set it gently onto the rear burner-support. The threaded studs on the bottom back of the burner must each fit through their respective holes in the rear burner-support. This is critical to the safe function of the barbecue. Finally, re-attach the cotter pins from step 3 around the studs (see Fig. 11-1).

MAIN BURNER AIR SHUTTER ADJUSTMENT

INSTALL THE VAPORIZER PANELS

Place the vaporizer panels directly on the support bracket above the burners. The panels allow heat from the burners to be evenly distributed throughout the cooking area. The panels are stainless steel and will heat and cool quickly, making your barbecue very responsive to the changes you specify in

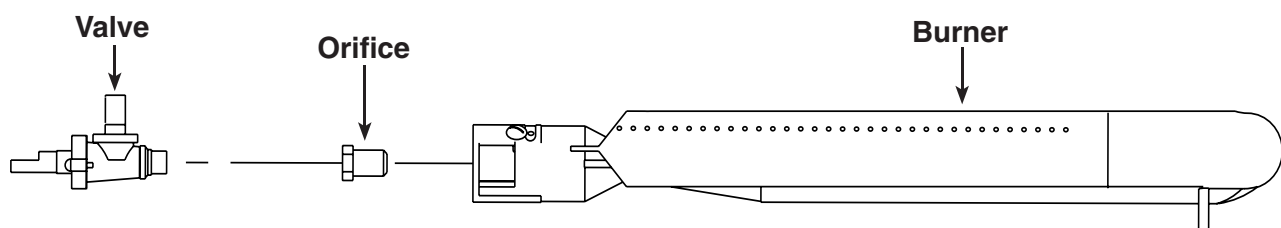

Fig. 11-3 - Burner orifice diagram

CHECKING/CONVERTING THE BURNER ORIFICES (Cont.)

grill temperature. They are rust resistant and may be cleaned with standard oven cleaners. Some discoloring will be seen with use. This is normal for stainless steel and does not affect the function.

ADJUSTING YOUR BARBECUE

Important: This appliance may not light or heat evenly or cook properly unless the air shutters are adjusted following installation (see AIR SHUTTER ADJUSTMENT on next page).

Burner air shutters are easily accessed by removing the front face panel. The air shutters are located on the front portion of each burner and have a locking screw that prevents the air shutter from inadvertent movement (see Fig. 12-1).

To close or open the air shutters, simply loosen the locking screw, using a long stemmed Phillips screwdriver, and turn the air shutter to open or close it.

Tighten the screws down when the desired setting is achieved.

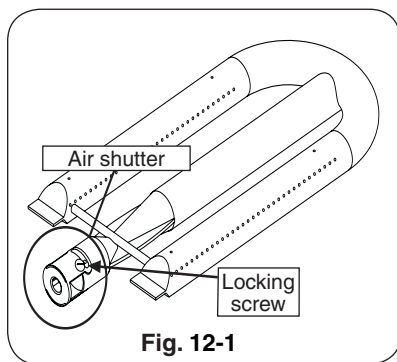

Fig. 12-1

AIR SHUTTER ADJUSTMENT

Light the burner to be adjusted in accordance with the LIGHTING INSTRUCTIONS and burn for 2 minutes with the burner control knob set to **HIGH** and the oven open. After burning for 2 minutes, open the air shutter until the flames lift off, or appear not to be touching the burner. Then begin closing the air shutter until the flames appear to burn while

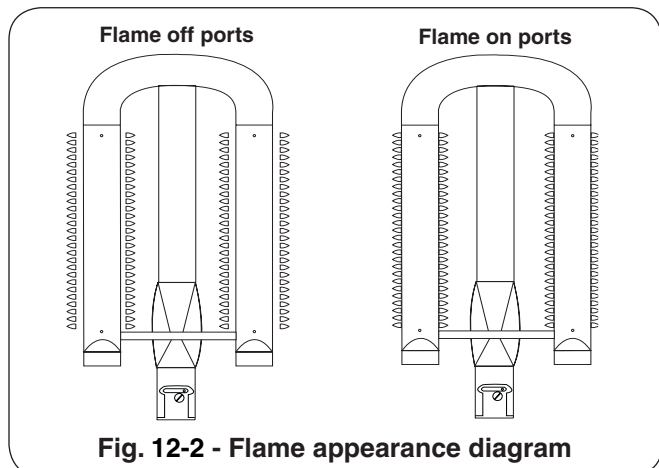

Fig. 12-2 - Flame appearance diagram

touching the burner ports (Fig. 12-2). You may then see short yellow tips on the flames. If flames are a lazy yellow, open the air shutters until the flame is blue with yellow tipping.

Note: Barbecues in some installations achieve a better air/gas mixture and will ignite more quickly if the valve is first turned beyond **HIGH** to **MEDIUM** or **LOW** for lighting.

BACKBURNER ORIFICE SIZE CHECKING/CONVERSION (IF EQUIPPED)

Before beginning, make sure you have the proper tools for the task.

This task requires:

- a 1/4" nutdriver
- a 3/8" wrench or socket screwdriver

Note: It may be necessary to remove the rotisserie rod before beginning this procedure.

1. Remove the backburner assembly as follows:

- a. Remove the backburner electrode mounting screw (1/4" hex) (see Fig. 12-3) and loosen the electrode. Draw the wire attached to the electrode down through the slot in the bottom of the bracket so that the left side of the backburner is free to be removed.
- b. Remove the backburner mounting screws (1/4" hex) located at the left end of the backburner assembly (see Fig. 12-3).

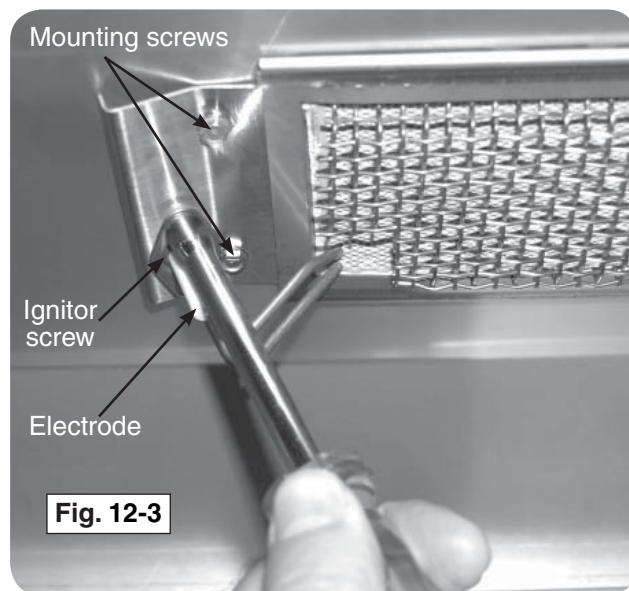
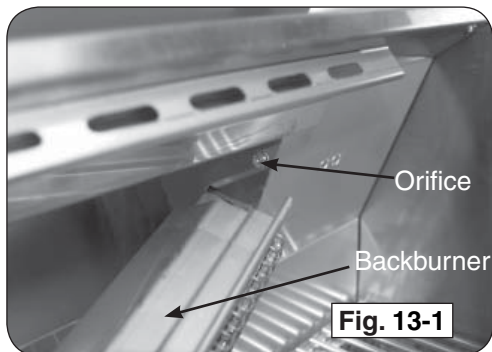

Fig. 12-3

Remove electrode and backburner mounting screws.

CHECKING/CONVERTING THE BURNER ORIFICES (Cont.)

- c. Carefully pull the left end of the backburner forward until the burner can be moved to the left pulling it free from the orifice located on the right side (see Fig. 13-1).
 - d. Using a $\frac{3}{8}$ " socket, remove the orifice from the orifice holder and check the number stamped on the face.
2. If an orifice change is necessary, replace the orifice with the correctly sized one.
 3. Replace the backburner assembly and the electrode by reversing the procedure in steps a. through c..



The backburner orifice can be seen on the right side after removing the backburner.

SIDEBURNER ORIFICE SIZE CHECKING/ CONVERSION (IF EQUIPPED)

Suggested Tools:

- a pair of needle-nose pliers
- a $\frac{5}{16}$ " hex nut driver

Note: It may be necessary to remove the rotisserie rod before beginning this procedure.

1. Lift the sideburner lid. Then remove the grill and sideburner cap and set them aside.
2. Locate and remove the cotter pin from the sideburner assembly underneath the sideburner shelf using needle-nose pliers (Fig. 13-2). Set it aside.
3. From the top of the sideburner shelf lift the sideburner upward while rotating the attached tubing underneath away from the orifice near the cart wall. Set it aside.

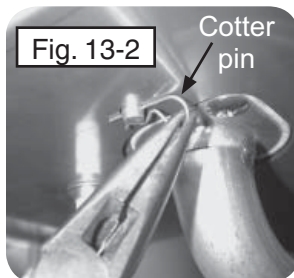

Note: To protect the manifold threads when placing the new orifice, start the threading manually, and then tighten with the nut driver.

4. Use the nut driver to remove the exposed orifice and replace it with the correct orifice for the gas being converted to. (see Table 1 for correct orifice sizes based on burner type and gas type).

Note: While the sideburner is still removed it may be convenient to adjust the sideburner air shutter.

5. Rotate the burner assembly back into place over the orifice so that the orifice is centered deeply into the burner pipe and the burner firmly seated in the shelf.
6. Re-insert the cotter pin underneath the sideburner assembly using needle-nose pliers. It may be necessary to push downward on the burner assembly from above to fully expose the cotter pin hole. Rotate the inserted cotter pin so that it is flush with the underside of the shelf.
7. Replace the burner cap by centering it on the sideburner assembly and making sure it drops in place.
8. Replace the grill with the grating running front to back so that it drops fully down onto the shelf, allowing the lid to close completely over it.

SIDEBURNER AIR SHUTTER ADJUSTMENT

The flames from a properly adjusted sideburner will touch the burner ports and appear mostly blue with light-yellow tips.

If the flames are orange, "lazy", or lift off the burner ports, then adjust the sideburner air shutter using the following steps (Fig. 13-3).

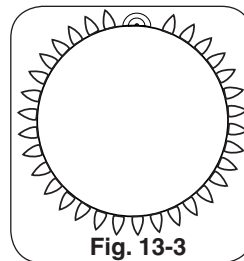

Sideburner adjustment is the most accessible (not requiring any hardware to be removed first)

and is located underneath the sideburner shelf on the left side of the barbecue, near the wall of the cart. The sideburner air shutter can safely and easily be adjusted while the sideburner is lit.

CAUTION: Do not touch the sideburner or the shelf immediately around it. They will be hot while adjusting the sideburner air shutter.

1. Light the sideburner following the lighting instructions in this manual.

2. Loosen the sideburner air-shutter adjustment screw, then use the tip of the screwdriver to open or close the air shutter until the flames appear blue and touch the burner ports. (Fig. 13-4).

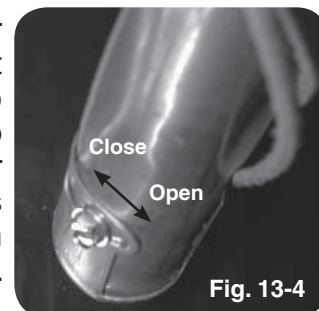

3. Re-tighten the adjustment screw.

ALLUMER DES INSTRUCTIONS (D'ALLUMAGE)

Lisez l'instruction entière avant que s'allumant et suivez ces instructions chaque fois vous lumière le barbecue.

ÉCLAIRAGE ÉLECTRONIQUE

1. Ouvrez tous les couvercles et enlevez toutes les couvertures des brûleurs que vous souhaitez vous allumer.
2. Arrêtez tous les boutons de commande de gaz à leurs positions.
3. Allumez le gaz à sa source.

Note: Aucune matière que la méthode d'éclairage vous emploient, n'allument pas le gaz à plus d'un brûleur à la fois. Les brûleurs adjacents de barbecue croix-mettront à feu et l'écoulement de gaz peut être restreint.

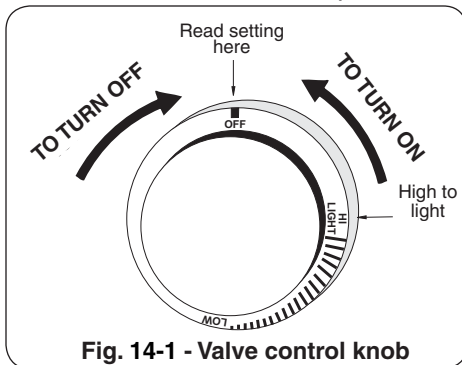

Fig. 14-1 - Valve control knob

ATTENTION: Si les brûleurs ne s'allument pas dans 5 secondes, enfoncez le bouton de commande et tournez le bouton à AU LOIN. ATTENDEZ 5 MINUTES avant de répéter l'étape 5. Si vous sentez le gaz suivez les instructions sur la couverture de ce manuel. Si les brûleurs ne s'allument toujours pas après que plusieurs tentatives, se rapportent aux instructions pour l'ÉCLAIRAGE MANUEL.

4. Enfoncez le bouton de commande pour que le brûleur soit allumé et tournez-le dans la position LÉGÈRE de HI, puis appuyez sur le bouton d'allumage. Une fois que le brûleur s'allume, libérez le bouton d'allumage.
5. Répétez l'étape 4 pour que chaque brûleur additionnel soit s'est allumé.

POUR LE PROPANE SEULEMENT

Les réservoirs de propane sont équipés d'un dispositif d'arrêt de sûreté qui peut ne pas causer le bas ou aucun gaz pressure/flame aux brûleurs si le fonctionnement et allumer des instructions ne sont pas suivis exactement (voir la note importante dans la section de dépannage pour plus de détails.)



Fig. 14-3 - Éclairage manuel

RAPPEL-VOUS: POUR L'ÉCLAIRAGE MANUEL SÛR, PLACEZ Un ALLUMEUR BRÛLANT D'ALLUMETTE OU De BUTANE PRÈS Du BRÛLEUR - ALLUMEZ ALORS Le GAZ (voyez Fig. 14-3).

Note: Les barbecues dans quelques installations réalisent un meilleur mélange d'air/gas et mettront à feu plus rapidement si le bouton de commande de brûleur est d'abord tourné au delà de la LUMIÈRE de HI au BAS pour l'éclairage.

ÉCLAIRAGE MANUEL

ATTENTION: Attendez toujours 5 minutes le gaz à l'espace libre après que n'importe quelle tentative non réussie d'éclairage.

1. Suivez les étapes 1 à 4 (à gauche).
2. Insérez un allumeur brûlant de butane de long-baril, une allumette brûlante de long-tige, ou une allumette brûlante tenue par un support de prolongation de fil (Fig. 14-2) par les grilles à cuire au brûleur (Fig. 14-3). Pour des backburners, tenez la flamme contre le matériel perforé du brûleur arrière. Pour des sideburners, tenez la flamme contre le brûleur.
3. Tout en tenant l'allumette ou la flamme plus légère à côté du brûleur, enfoncez le bouton de commande approprié



Fig. 14-2 - Support d'allumette

de brûleur et tournez-le dans le sens contraire des aiguilles d'une montre dans la position LÉGÈRE de HI. Quand les lumières de brûleur, enlèvent l'allumeur ou s'assortissent.

4. Si le brûleur ne s'allume pas, enfoncez **immédiatement** le bouton et tournez le bouton de commande de brûleur à AU LOIN. ATTENDEZ 5 MINUTES avant de répéter les étapes 2 à 4 des INSTRUCTIONS MANUELLES d'ÉCLAIRAGE.

COUPER LE GRIL

Pour couper le gril, enfoncez chaque bouton de commande de valve et tournez-le dans le sens des aiguilles d'une montre à la position de repos.

Fermez toujours la valve à l'offre de gaz après chaque utilisation du barbecue.

AJUSTEMENT DE LA FLAMME

Les boutons sur le visage du barbecue commandent les valves et ajustent la taille de flamme. La première position marquée est éteinte, la deuxième LUMIÈRE de HI, et la troisième BAS. Entre la LUMIÈRE de HI et les BASSES étiquettes sont les marques de point médian. La taille de flamme peut être placée n'importe où entre la LUMIÈRE de HI et les BAS arrangements.

La taille de la flamme avec une valve en BASSE position peut être encore réglée à l'aide d'une petite vis de réglage au centre de la tige de valve. Cette vis est accessible en enlevant le bouton de valve, qui tire immédiatement l'extrémité de la tige de valve.

LIGHTING (IGNITION) INSTRUCTIONS

Read entire instructions before lighting and follow these instructions each time you light the barbecue.

ELECTRONIC LIGHTING

1. Open all lids and remove all covers from the burners you wish to light.
2. Turn all gas control knobs to their **OFF** positions.
3. Turn on the gas at its source.

Note: No matter which lighting method you use,

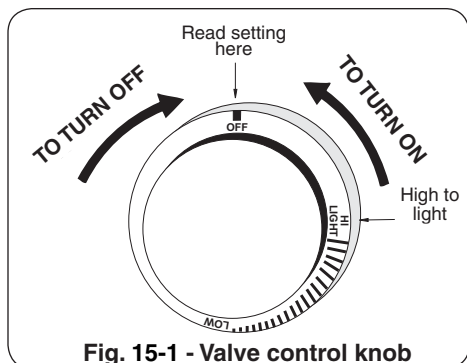

Fig. 15-1 - Valve control knob

DO NOT turn on the gas to more than one burner at a time. Adjacent barbecue burners will cross-ignite and gas flow may be restricted.

CAUTION: If the burners do not light within 5 seconds, depress the control knob and turn the knob to **OFF**. WAIT 5 MINUTES before repeating step 4. If you smell gas, follow the instructions on the cover of this manual. If the burners still do not light after several attempts, refer to the instructions for MANUAL LIGHTING.

4. Depress the control knob for the burner to be lit and turn it to the **HI LIGHT** position, then press the ignition button. Once the burner lights, release the ignition button.
5. Repeat step 4 for each additional burner to be lit.

FOR PROPANE ONLY

Propane tanks are equipped with a safety shut-down device that may cause low or no gas pressure/flame at the burners if operating and lighting instructions are not followed exactly (See important note in the TROUBLESHOOTING section for more details.)

ADJUSTING THE FLAME

The knobs on the face of the barbecue control the valves and adjust the flame height. The first labeled position is **OFF**, the second **HI LIGHT**, and the third **LOW**. In between the **HI LIGHT** and **LOW** labels are mid-point marks. Flame height can be set anywhere between the **HI LIGHT** and **LOW** settings.

The height of the flame **with a valve in LOW position** may be further regulated by means of a small adjusting screw in the center of the valve stem. This screw is accessible by removing the valve knob, which pulls straight off the end of the valve stem.

MANUAL LIGHTING

CAUTION: Always wait 5 minutes for gas to clear after any unsuccessful lighting attempt.

1. Follow steps 1 through 4 (left).
2. Insert either a burning long-barrel butane lighter, a burning long-stem match, or a burning match held by a wire extension holder (Fig. 15-2) through the cooking grids to the burner (Fig. 15-3). For backburners, hold the flame against the perforated material of the backburner. For sideburners, hold the flame against the burner.
3. While holding the match or lighter flame next to the burner, depress the appropriate burner control knob and turn it counterclockwise to the **HI LIGHT** position. When the burner lights, remove the lighter or match.

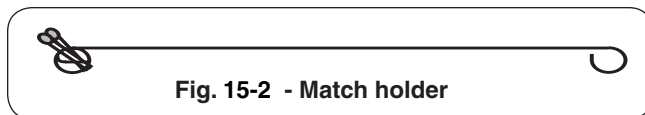

Fig. 15-2 - Match holder

4. If the burner does not light, **IMMEDIATELY** depress the knob and turn the burner control knob to **OFF**. WAIT 5 MINUTES before repeating steps 2 through 4 of the MANUAL LIGHTING INSTRUCTIONS.

Note: Barbecues in some installations achieve a better air/gas mixture and will ignite more quickly if the burner control knob is first turned beyond **HI LIGHT** to **LOW** for lighting.



Fig. 15-3 - Manual lighting

REMEMBER: FOR SAFE MANUAL LIGHTING, PLACE A BURNING MATCH OR BUTANE LIGHTER BESIDE THE BURNER - **THEN TURN ON THE GAS** (see Fig. 15-3).

SHUTTING OFF THE GRILL

To shut off the grill, push in each valve control knob and turn it clockwise to the **OFF** position.

Always close the valve to the gas supply after each use of the barbecue.

BARBECUE SAFETY INFORMATION & MAINTENANCE

Each time you use the barbecue, make sure that:

1. The area around the barbecue is clear of flammable vapors, liquids, and substances such as gasoline, yard debris, wood, etc.
2. There is no blockage of the air flow through the vent space located below the face of the unit.
3. When using propane gas:
 - a. The special ventilation openings in the enclosure are kept free and clear of debris (see PLANNING THE LOCATION OF THE BARBECUE).
 - b. If connected to a propane cylinder, the rubber hose attached to the regulator is carefully inspected before each use.
 - c. The propane cylinder, regulator, and rubber hose are installed in a location not subject to heating above 125° F (51° C).
4. The burner flames burn evenly along both sides of each burner with a steady flame, which is mostly blue with yellow tipping. (Refer to section on AIR SHUTTER ADJUSTMENT.) If burner flames are not normal, check the orifice and burner for insects or insect nests.
5. The in-line gas valve or gas cylinder valve is always shut **OFF** when the barbecue is not in use.
6. The drip collector hole is clear and unobstructed. Excessive grease deposits can result in a grease fire.
7. The barbecue is free and clear from combustible materials, gasoline, and other flammable vapors and liquids.

DRIP COLLECTION SYSTEM

The drip collector in this barbecue is part of the unit's main frame and is located below the burners. The drip collector has one hole that will allow excess drippings to fall through during cooking, while separating the firebox from the drip tray. Clean the drip tray after each use.

The drip collector allows you to brush or scrape residue from the barbecue's inner liner into the drip tray. Following the manufacturer's instructions and regular cleaning of the barbecue's interior with oven cleaner, will help to prevent grease fires.

Periodically, check the burners to make sure they are clear of debris. Properly adjusted burner flames burn evenly along both sides of each burner with a steady flame (mostly blue with yellow tipping). If burner flames are not normal, check the orifice and burner for insects or insect nests. (See section on CHECKING/CONVERTING THE BURNER ORIFICES for instructions on burner removal and replacement.)

Check the burner ports at least annually for blockage by removing the burner (see orifice changing instructions) and visually inspect the gas intake tube for insects and nests. A clogged tube can lead to a fire beneath the grill.

WARNING

NEVER cover the *entire* cooking or grill surface with griddles or pans. Overheating will occur and burners will not perform properly when combustion heat is trapped below the cooking surface.

CAUTION: NEVER spray water on a hot gas unit.

ROTISSERIE INSTRUCTIONS

USING THE BACKBURNER AND ROTISSERIE

Rotisserie cooking with the backburner is accomplished without use of the main burners. Follow the steps in the appropriate sections below to set up and use these accessories.

SET UP

1. Remove the cooking grids from the barbecue, if necessary, to obtain maximum clearance for larger cuts. The flavor grids may also be removed if required.

Tip: Aluminum foil or a baking pan may be placed over the main burners, a little forward of center, to catch excess drippings from the meat.

2. Attach the rotisserie motor to the rotisserie mounting on the right side of your barbecue by sliding the bracket attached to the motor housing onto the tab on the right of the barbecue so that the spit rod will fit into the motor drive socket from the left.
3. Follow the LIGHTING INSTRUCTIONS to light the backburner.
4. Allow the backburner to preheat for approximately 10 minutes on **HI LIGHT** setting.

PUTTING THE MEAT ON THE SPIT ROD

1. Slide the meat and spit prongs onto the spit rod so the meat is centered and balanced as well as possible.
2. Tighten the spit prongs into place so that the meat remains in a fixed position on the rod and the meat rotates with the rod.

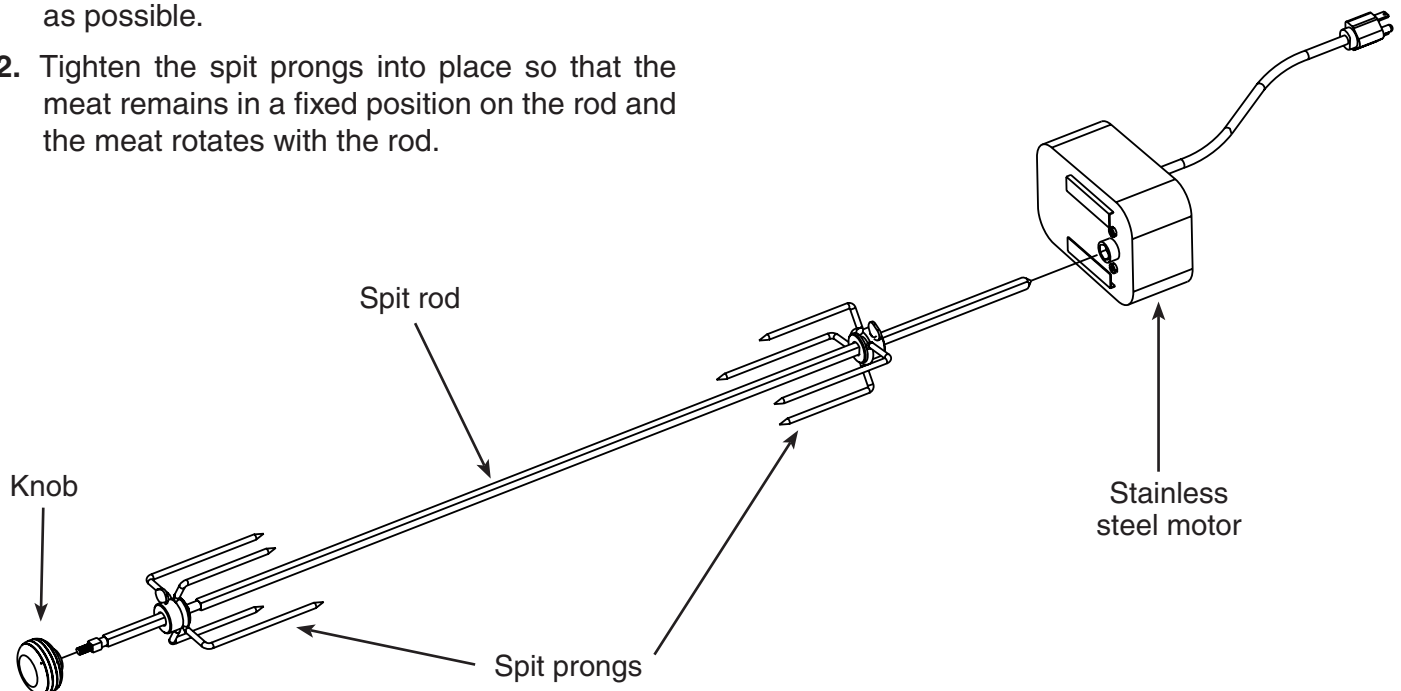

RUNNING THE ROTISSERIE

1. Place the pointed end of the spit rod into the motor drive socket and rest the handle end of the spit rod in the spit bracket on the right side of the barbecue.
2. Plug in (if necessary) and turn on the rotisserie motor.
3. Use a standard roasting guide to estimate the length of time for your meat. A meat thermometer may also be used to tell when your favorite cuts are cooked to your liking. When testing temperatures with a thermometer, turn off the rotisserie motor and turn the backburner on **LOW**. This will keep the meat from over cooking on one side.

Note: When burning properly, the backburner grating will glow red. The first time it is used the backburner may smoke a little.

Important: Operate the backburner with the oven closed. This simulates an oven effect and helps your meat cook faster. Constant rotation of the spit assures even cooking and maximum retention of juices.

Note: On large cuts of meat or whole turkeys, it may be necessary to reduce the heat from your backburner. Cooking food at a lower temperature for a longer period of time will keep the outer surface from burning while cooking the interior of the meat.

RIGID SHELF INSTALLATION

This barbecue comes with two (2) rigid shelves that must be attached. These can be attached using the four support screws provided and a Phillips-head screw driver.

1. Insert the top two screws into the side of the barbecue and screw them in about half way.
2. Line up the larger, bottom portion of the two keyhole openings with the two top screws and fit the two keyhole openings over the two screws. With the shelf pushed all the way against the side of the barbecue, lower the shelf so that the screws lock into the narrower, upper portions of the keyholes.

Note: The shelf will now stay in place on it's own.

3. Insert the bottom two screws into their holes and tighten them all the way.
4. Finally, tighten the upper two screws, completely.

To detach, reverse the process above.

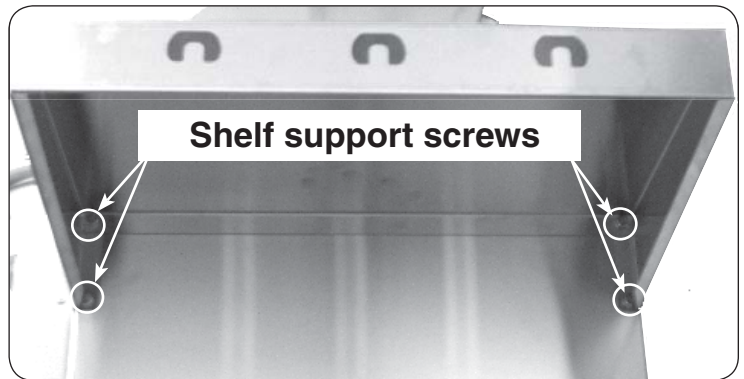

View from under right shelf

ACCESSORIES

USING THE GRILL SCRAPER

The triangular stainless-steel piece with serrated edges is designed to be used as a tool to quickly and easily scrape food particles and drippings off the grill after barbecuing. To use it, simply align one of the edges of the scraper so that the cooking grid bars fit into the grooves in the serrated edge, and then scrape it along the length of the cooking grid. Repeat as needed.

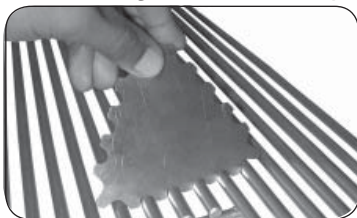

Fig. 19-1
Grill scraper use

WARMING RACK

The warming rack (Fig. 19-2) is packed separately with the barbecue.

To install the warming rack, lift the front of the rack up slightly and insert the rack hangers into the two holes in the back of the barbecue above the backburner. Then lower the front of the rack into a level position to lock the rack in place.

To remove the warming rack, lift up on the front of the rack until the rack hangers pull free from their supporting holes.

Note: For best results, remove the warming rack before using the rotisserie.

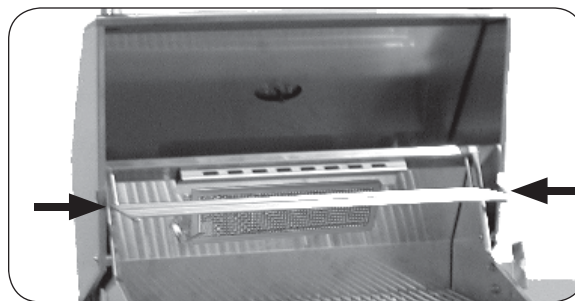

Fig. 19-2 Warming rack in place inside oven

USING THE COOKING GRILL LIFTER

Hold the grill lifter by gripping the center section with the prongs pointing down (use an oven mitt or heavy glove if the grill is hot). Insert the notched end of the grill lifter into the grill, in front of the midway point (front to back-Fig. 19-3), and central (left to right-Fig. 19-4). Twist the grill lifter (clockwise or counterclockwise) so the handle is parallel to the grill rods. This “seats” the spiked end of the grill lifter between two rods, enabling you to safely lift the grill out of the barbecue. Lift slowly and adjust the grill lifter, if necessary, to balance.

DRIP PAN

The drip collection system allows you to brush or scrape excess dried residue inside the barbecue directly into the drip pan (see PARTS LIST for drip pan location). To simplify cleanup when using the rotisserie, you may place a baking pan or foil under the rotisserie to collect the drippings. Clean the drip pan after each use.

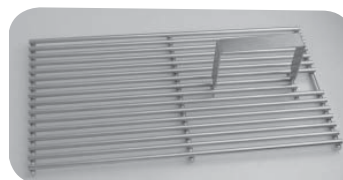

Fig. 19-3
Placement of the grill lifter in grill

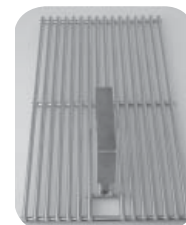

Fig. 19-4

THE VAPORIZER PANEL(S)

Place each vaporizer panel directly on a burner or burner pair. Center each panel over the burner, oriented as shown in Fig. 19-5.

Note: This allows heat from the burners to be evenly distributed throughout the cooking area. The vaporizer panels heat and cool quickly, making the barbecue very responsive to the changes in heat from the burners.

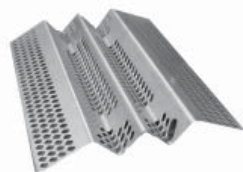

Fig. 19-5

BARBECUE CARE & CLEANING

CARE AND CLEANING

The new AOG barbecue represents the latest and most advanced technology available. In order to continue to enjoy the benefits of this technology and to protect your investment, we recommend the following:

Cover your barbecue when not in use.

Clean the unit with a quality stainless steel cleaner at least once a month (see Fig. 20-1).

Note: In a humid environment, due to the nature of stainless steel, iron oxide deposits may appear. Do not be alarmed – these deposits are removable with stainless steel cleaner during periodic maintenance.

Check the burner ports at least annually for blockage by removing the burner (see orifice changing instructions) and visually inspecting the gas intake tube for insects and nests. A clogged tube can lead to a fire beneath the grill.

The inside of the barbecue may be cleaned periodically with oven cleaner if desired. Follow the oven cleaner instructions for proper use.

By following these recommendations, you will enjoy the beauty and power of your barbecue for many years to come.



Fig. 20-1 - Wipe with grain

BARBECUE COVER

PROTECTING YOUR BARBECUE

An optional heavy-duty cover will protect the finish on your barbecue and preserve your investment. The water repellent material will shield your barbecue from corrosion and oxidation.

To provide a custom fit, each cover has been cut and sewn by hand for a particular smoke oven model. Make sure to give the model number of your barbecue when ordering a cover from the manufacturer or your local dealer.

To maintain and protect your barbecue cover, occasionally wipe the outside with a sponge soaked

in water and a mild household detergent or cleaner, and rinse with a clean damp cloth.

Important: Allow your barbecue to cool before covering.

Important: Always close the gas supply shut off valve to the barbecue. If storing the barbecue for a long period of time, disconnect the barbecue from the gas supply completely.

Always check the burners after long periods of disuse to look for obstructions that may hamper performance and safe operation of your barbecue.



Fig. 20-2

REPLACING THE IGNITOR BATTERY

1. Remove the ignitor cover by turning it counterclockwise.



Important: Do not attempt to pull or turn the rubber cap.



2. Remove battery for replacement. The battery is re-installed with the negative (-) end out.



3. After properly inserting the battery, replace the ignitor cover by turning the cap clockwise.



Note: If you have accidentally removed the rubber cap, follow the instructions below to replace it.

1. Pull the rubber cap and the inner plastic sleeve apart.
 2. Carefully insert the rubber cap into the plastic sleeve so it sits behind inner lip.
 3. Turn the cap over and slide the inner plastic sleeve into the cap.



TROUBLESHOOTING

If you have trouble with the gas barbecue, please use this list to identify the problem. By trying one or more of the solutions to the possible cause you should be able to solve the problem. If this list does not cover your present problem or if you have other technical difficulties with the barbecue, please contact your local barbecue dealer.

PROBLEM	POSSIBLE CAUSE	CORRECTION
Ignition system failure	1) Improper air shutter adjustment	1) Adjust air shutters.
	2) Ignition wire disconnected	2) Re-plug wires into generator.
	3) Low gas pressure	3) Adjust or replace battery.
	4) Dead battery	4) Replace battery.
Insufficient heat	5) Improper air shutter adjustment	5) Adjust air shutters.
	6) Using propane orifice for natural gas	6) Change orifices.
	7) Low gas pressure/flame (natural)	7) Have gas company check the operating pressure at the barbecue.
	8) Low gas pressure/flame (propane)	8) Reset propane tank safety*: Shut off all valves including propane tank and follow lighting instructions exactly.
Uneven heating	9) Burner ports partially blocked by debris	9) Remove burners and clean out ports.
	10) Small spiders or insects in burner	10) Inspect burners for spider webs or other debris that may block gas flow.
Rotisserie noisy	11) Rotisserie out of balance	11) Adjust the meat on the spit rod.

Troubleshooting Table

Note: *Propane tanks are equipped with a safety shut-down device that may cause low or no gas/flame at the burners if operating and lighting instructions are not followed exactly. If you suspect the propane tank safety shut-off is in effect, shut off all burner control valves and the propane tank valve. Then read and follow the LIGHTING INSTRUCTIONS exactly. Lighting instructions are located in the owner's manual and printed on the barbecue's metal drip tray. If the problem persists continue troubleshooting or contact your local dealer or R. H. Peterson for assistance.

**AMERICAN OUTDOOR GRILL
LIMITED WARRANTY**

**American Outdoor Grill stainless steel burners are warranted for 15 YEARS
All other American Outdoor Grill parts are warranted for 10 YEARS**

Except as noted below

American Outdoor Grill ignition systems (excluding batteries), accessories (including sideburners, motors, and thermometers), and vaporizer panels are warranted for one year from the date of purchase.

This warranty applies only to the original purchaser with invoice or proof of purchase and covers American Outdoor Grill products intended for residential usage only. It does not apply to rust, corrosion, oxidation, or discoloration, which may occur due to moisture or overheating, unless the affected component becomes inoperable. It does not cover parts becoming defective by misuse, accidental damage, improper handling, improper installation, improper service, or electrical damage. It does not cover labor or labor-related charges. It specifically excludes liability for indirect, incidental or consequential damages. Some states do not allow the exclusion or limitation of incidental or consequential damages, so the above exclusion or limitation may not apply to you.

This warranty gives you specified legal rights and you may have other rights which may vary from state to state.

For additional information regarding this warranty, or information on how to place a warranty claim, contact your authorized American Outdoor Grill dealer.

American Outdoor Grills
P.O. Box 4053, La Puente, CA 91747

Please keep a copy of your sales slip for proof of purchase.

ROBERT H. PETERSON CO.

Quality Check

Date: _____

Orifice # (Main): _____

Orifice # (Other): _____

Leak Test: _____

Burn Test: _____

Gas Type: NAT. / PROPANE

Model #: _____

Serial #: _____

Air Shutter: _____

Inspector: _____